



# UNO Electric Stacker 1.5 tonne

**STACK MORE. DELIVER MORE**

---

# ONE TRUCK SERVES ALL

Godrej Electric Stacker are economical and versatile equipment for light (up to 1.5 tonne) load handling needs across your warehouse. It moves quickly, ensuring maneuverability even in tight spaces, lifts to a great height, and above all, is easy to operate and doesn't necessitate formal training.

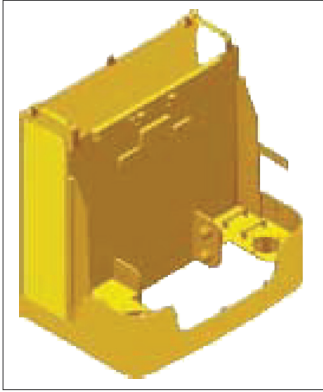

## Heavy duty construction

An 8 mm carbon steel chassis protects the drive train, hydraulic pack and controller from damage during operations

## Industry-leading lifting capacity

The interlocking construction guarantees rigidity and stability to lift a maximum of 650 kilograms up to 6.3 meters high

## Easy access to controls

- A full-function control handle with thoughtfully placed switches allows the operator to intuitively manage all functions (Forward/Reverse/Braking/Lifting/Lowering) and pay attention to driving and handling
- The symmetrical design of the handle makes it equally suitable for left and right-handed operators

## Better visibility all around

A superior mast design with excellent fork tip visibility ensures confident maneuvering in tight spaces and while loading or unloading

## Accurate and efficient load handling

- The proportional control valve ensures the forks are aligned accurately with the pallet for jerk-free and safe lifting and lowering
- The electronic control generates only the power required to lift the load - an energy efficient solution that save battery and delivers longer uptime



## Fully integrated AC Traction System (ACTS)

- The AC control system with the rugged drive train allows fast acceleration and quick direction change while protecting the gearbox
- It keeps the equipment under fine control at low speed for pallet picking and placing
- The motor torque control provides a strong braking force, dramatically reducing brake pad wear from applying brakes



# EASIER AND SAFER WAY TO LIFT, CARRY OR MOVE

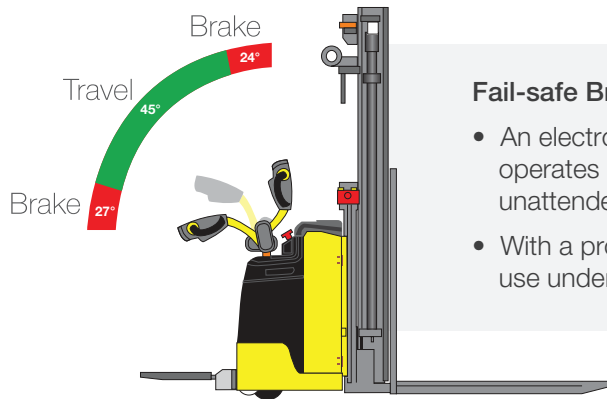

## Fail-safe Braking System

- An electromagnetic brake acts automatically in case of power failure. It also operates as a ramp hold, preventing the machine from moving if left unattended on a slope
- With a programmable braking system, Godrej Electric Stackers are easy to use under any working conditions or operator skills

## Anti-pinning button at the end of the control handle

If the operator accidentally gets trapped between the stacker and the wall/rack, the anti-pinning button presses against the operator. This immediately moves the machine a few inches away from the operator, before coming to a halt

## Turtle speed switch

The Turtle speed switch ensures precise handling and efficient operations even at the lowest speed

## Auto speed reduction

The controller automatically reduces machine speed when the forks are raised to 300 mm above the ground. This safeguards the load and ensures effortless transportation

## Battery Discharge Indicator (BDI) with lift lockout

To prevent deep discharge of the battery, BDI prompts the operator to put the battery on charge when it is discharged to 20% of its total capacity

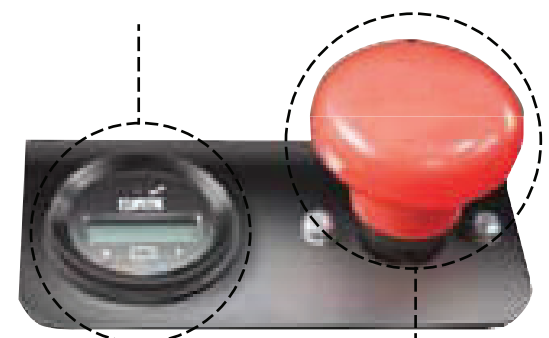

## Emergency stop switch

The mushroom button instantly cuts the power supply to all functions and activates the electromagnetic brake in case of an emergency

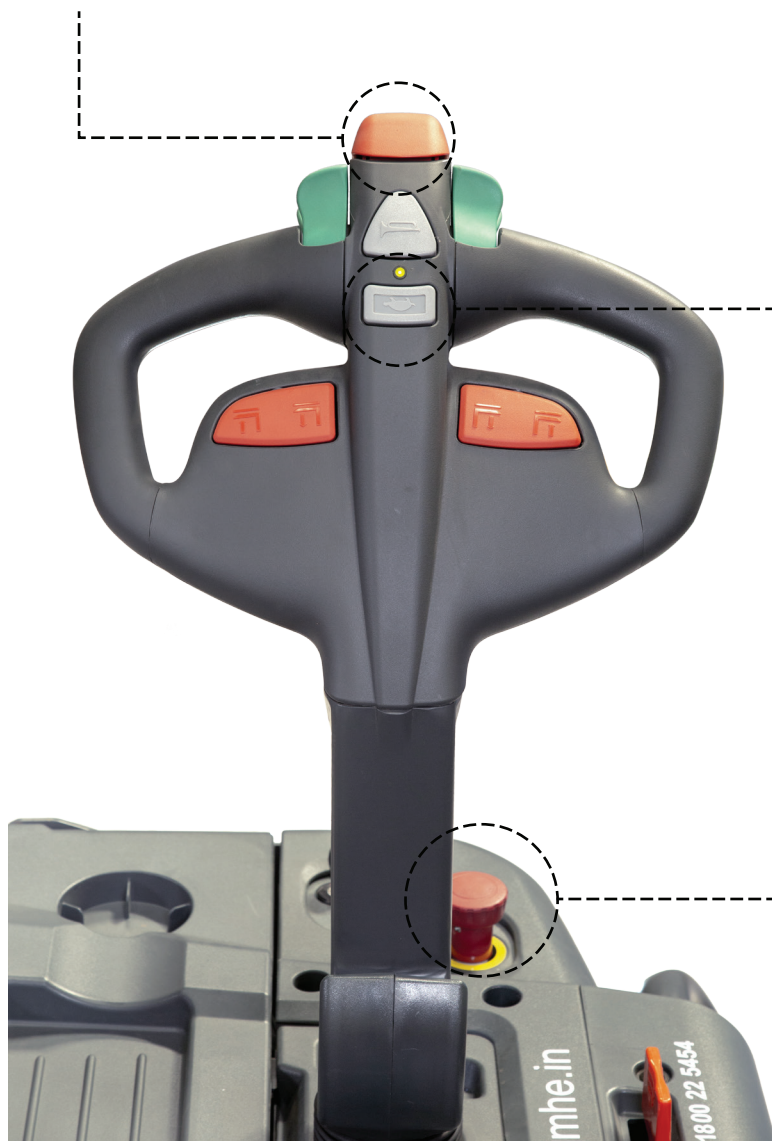



## STANDARD INCLUSIONS AND OPTIONAL ACCESSORIES

---

- 24 V Electrical System
- Anti Pinning Button for Operator Safety
- Battery Discharge Indicator and Hour Meter
- Center mounted fully functional control handle
- Easy Auto-fill system for battery (optional)
- Electromagnetic Brake on Traction Motor with Ramp Hold facility
- Electromagnetic Parking Brakes
- Fully Integrated Drive Unit with Gear Box, Traction Motor and Drive Wheel
- Horn
- Load back rest
- Mushroom Button for Emergency Shut Down
- Operator Platform
- Side restraints

# TECHNICAL SPECIFICATION

Characteristics	1.1	Manufacturer		Godrej
	1.2	Model		ES15 UNO   ES 15 W UNO
	1.3	Power unit		Electric
	1.4	Operation		Pedestrian
	1.5	Rated traction weight	Q (t)	1.5
	1.6	Load centre	c (mm)	600
	1.8	Axle centre to fork face	x (mm)	695
	1.9	Wheel base	y (mm)	1190
Wheels / Tyres	2.1	Service weight with battery	kg	927
	3.1	Wheels type		Polyurethane
	3.2	Driving wheel size	Φ×w(mm)	Φ250×80
	3.3	Bearing wheel size	Φ×w(mm)	Φ80×70
	3.4	Additional wheels (dimensions)	Φ×w(mm)	Φ150×58
	3.5	Wheels, number front/rear (x = driven)		1, 4/2
	3.6	Track width- Front	b <sub>10</sub> (mm)	685
Dimensions	3.7	Track width- Rear	b <sub>11</sub> (mm)	520
	4.1	Maximum Fork Lift	h3 (mm)	Refer Table 1
	4.2	Height of mast, lowered	h1 (mm)	Refer Table 1
	4.3	Free lift	h2 (mm)	NIL
	4.5	Height of mast, extended	h4 (mm)	3687
	4.15	Lowered forks height	h <sub>13</sub> (mm)	86
	4.19	Overall length without footboard	l <sub>1</sub> (mm)	1935
	4.20	Overall length with footboard	l1' (mm)	2385
	4.21	Overall width	b1 (mm)	820
	4.22	Fork dimensions	s/e/l (mm)	60/180/1150
	4.25	Width across the forks	b5 (mm)	570   695
	4.32	Min.Ground clearance	m <sub>2</sub> (mm)	25
	4.33	Aisle width with pallet 1000 x 1200 across forks	Ast (mm)	2335/2820
	4.34	Aisle width with pallet 800 x 1200 along forks	Ast (mm)	2305/2790
	4.35	Min.Turning radius	Wa (mm)	1460
Performance	5.1	Travel speed,laden/unladen	(km/h)	5.2/5.5
	5.2	Lifting speed, with/without load	(mm/s)	100/135
	5.3	Lowering speed, with/without load	(mm/s)	146/128
	5.8	Maximum climbing ability, with/without load	(%)	6/8
	5.10	Service brake		Electromagnetic
Drive	6.1	Drive motor, 60 minute rating	(kW)	1.5
	6.2	Lift motor rating at S3 15%	(kW)	2.2
	6.4	Battery voltage/rated capacity	(V/Ah)	24/240
	6.5	Battery weight (± 5%)	(kg)	210
Other	8.1	Type of drive control		AC Drive
	8.4	Noise level at operator's ear	(dB(A))	≤70

Table 1

	Model	Mast Type	Maximum Fork Height (MFH) mm	Overall Height Lowered OAHL mm	Overall Height Raised OAGR mm	Capacity at MFH Kg
1	ES 1532 UNO/ ES 1532 W UNO	2 Stage CVM	3200	2127	3787	1100
2	ES 1536 UNO/ ES 1536 W UNO	2 Stage CVM	3600	2327	4087	900
3	ES 1540 UNO/ ES 1540 W UNO	3 Stage CVM	4000	1886	4496	700



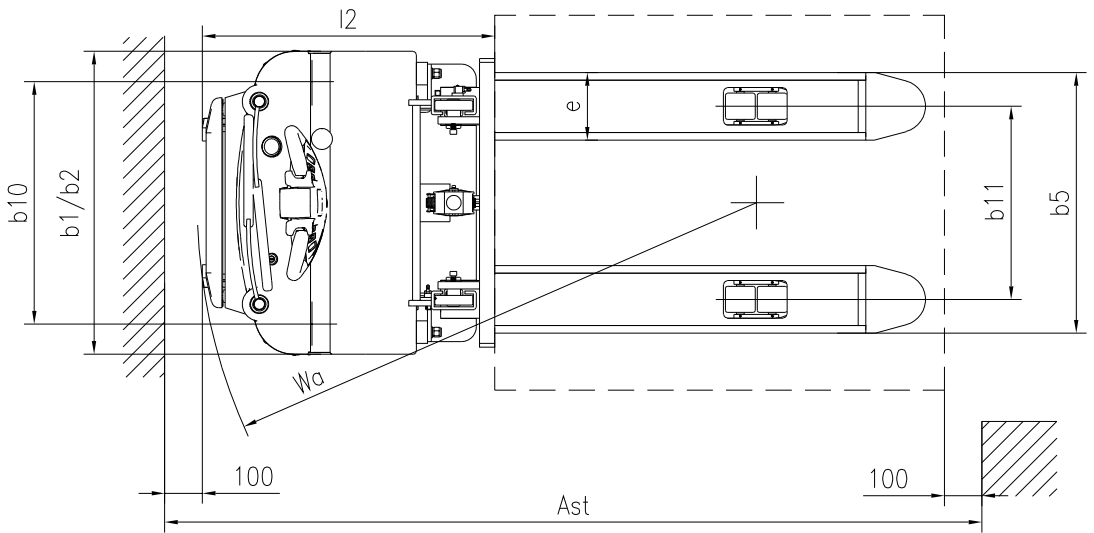
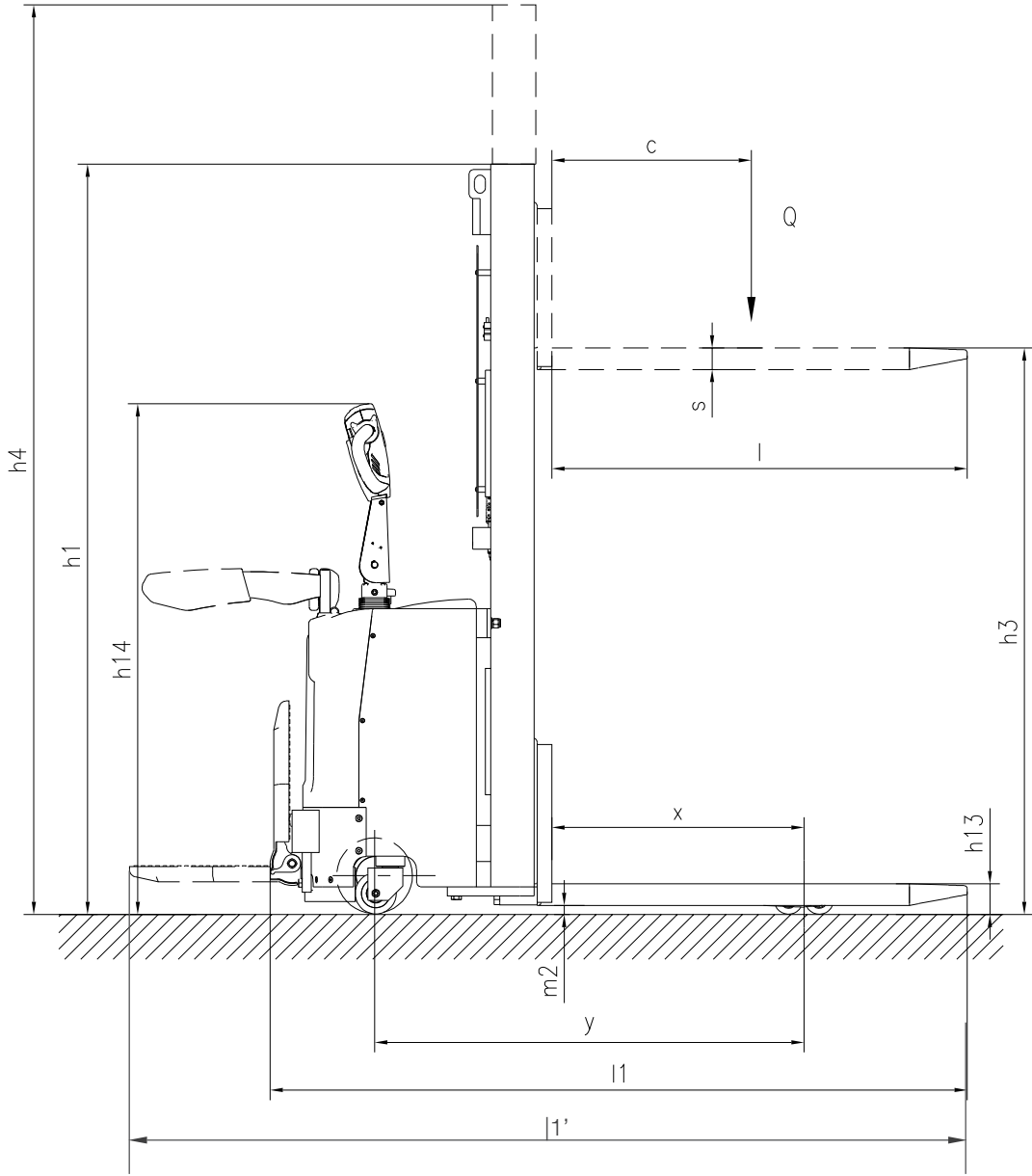

## DEALER CONTACT DETAILS – KENYA & UGANDA

**GANATRA**  
**PLANT & EQUIPMENT LTD.**



**Baba Dogo Road, Ruaraka,  
Nairobi**

**Tel: +254723506911**

**Email: *info@godrej.co.ke***

**Pioneer house, Showroom 4  
Plot 28, Jinja road, Kampala**

**Tel: +256770660449**

**Email: *info@godrej.co.ke***